

Small A-Frame Glass Cart

Athletica O&M manual

Thank you for purchasing the Small A-Frame Glass Cart

For your safety, please ensure you read these instructions carefully before using. Keep these instructions attached to the cart at all times for reference.

This manual details the assembly and operation of the Small A-Frame Glass Cart.

Contact Athletica Sport Systems at 1.877.778.5911 for all replacement parts.

Component List

Item	Description	Quantity
1	A-Frame cart base	1
2	A-Frame cart ends	2
3	Cross members	6
	3/8" x 3-1/2" hex bolts	4
	3/8" x 1" hex bolts	12
	3/8" flat washers	32
	3/8" Nylon lock nuts	16
	Nylon ratchet straps	2

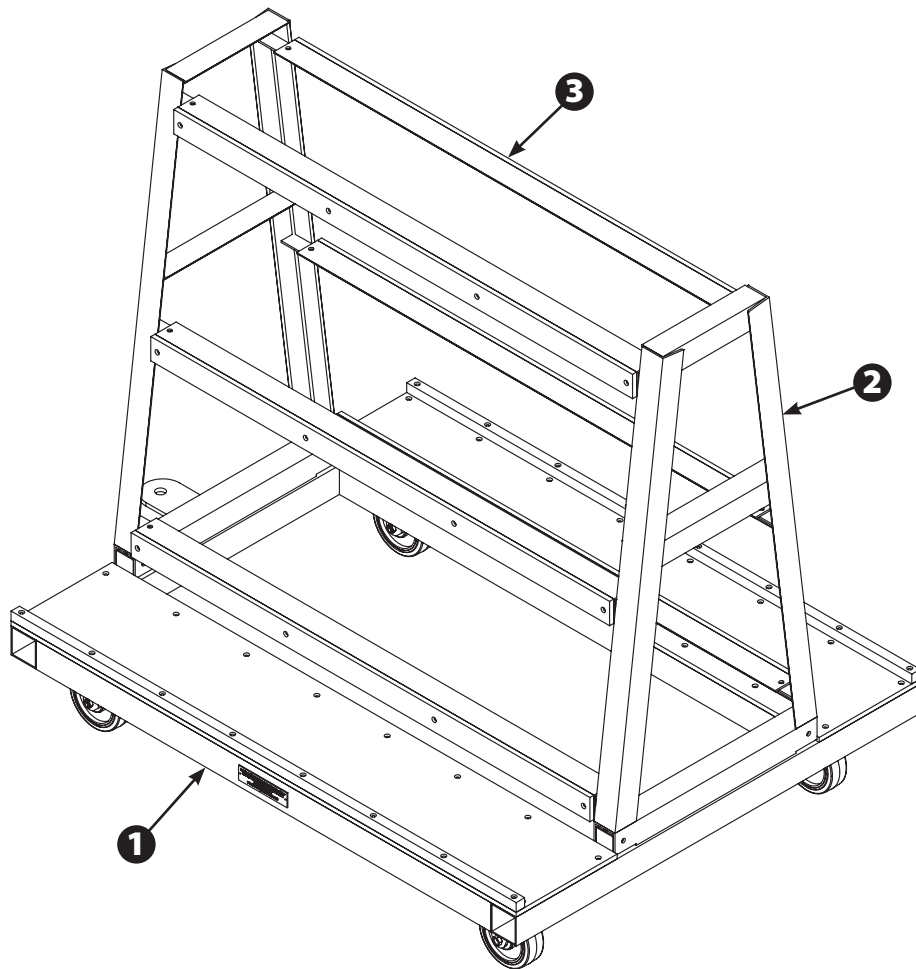

Assembly

1. Unpack all materials in a clean and well lighted work area. Please refer to component list table for list of parts provided.
2. Place A-Frame cart ends on top of cart base as shown below. Fasten in place with 3/8" x 3 1/2" hex bolts, 3/8" flat washers and 3/8" nylon lock nuts provided. Tighten the nuts on only finger tight at this point.

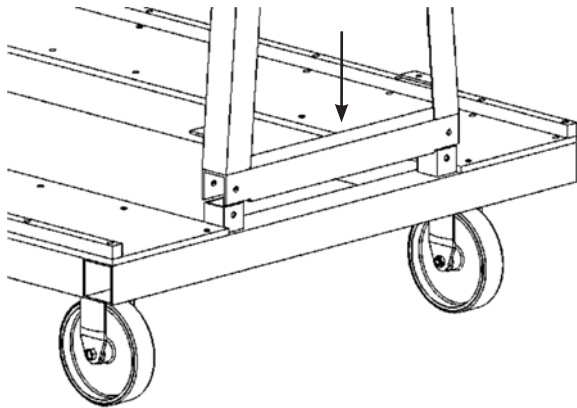

3. Place cross members between A-Frame ends as shown. Fasten in place to flatbar gussets using 3/8" x 1" hex bolts, 3/8" flat washers and 3/8" Nylon lock nuts provided. Repeat for all 6 cross member pieces.

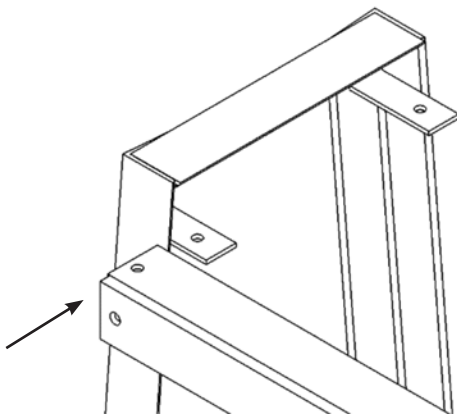

4. Tighten all 3/8" fasteners put in place during steps 3 and 4 using a 9/16" wrench and socket.

5. Take nylon ratchet strap and stretch to the opposite A-Frame end of where the ratcheting mechanism is attached. Wrap the hook around the angle on the A-Frame end as shown.

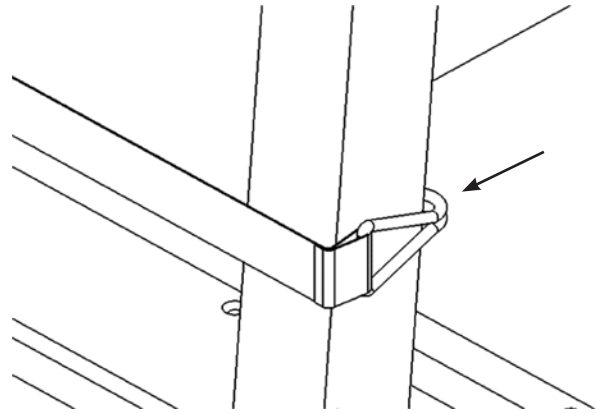

6. Tighten nylon strap using the ratchet at the opposite end of the hook on the nylon strap.
7. Your A-Frame cart is now ready to use.

Please continue reading this manual for important operational safety information.

Engineer Stamped Drawing

Upon request, an engineer stamped drawing will be provided to you which describes the dimensions of the Cart and identifies its Safe Working Load Rating.

Name Plate

Please refer to the name plate attached to the cart, which states the Safe Working Load Rating for this cart, as well as the web site address and toll-free number of Athletica Sport Systems. Please contact us with any questions regarding this product. You can reach us at 1.877.778.5911 from 8:00 a.m. - 5:00 p.m. Eastern Time, Monday through Friday.

What is the “Safe Working Load Rating”?

The Safe Working Load Rating is the maximum weight that can be loaded onto one (1) cart (the maximum weight includes the weight of the cart itself - 1000lbs). It is extremely important that the load placed on any A-Frame cart does not exceed the applicable Safe Working Load Rating. Overloading can lead to failure of the A-Frame cart potentially causing damage to the item(s) loaded on it and possible severe personal injury or death. Charts provided on the next page outline the typical weights of various sizes of glass and acrylic as well as the maximum number of pieces of material that can be placed on either side of the cart. If you are unsure about the safe working load rating for the A-Frame cart you have purchased contact us at 1.877.778.5911.

Safe Operation and Use of this Small A-Frame Cart

1. When lifting materials on and off of the A-Frame cart use proper lifting techniques to avoid personal injury.
2. Ensure work area is clean and well lighted while loading and unloading the A-Frame cart.
3. It is important that the cart is positioned on a level floor that is clear and dry and free of debris. If the cart is not positioned on a level floor, loads placed upon or removed from it could fall, potentially causing damage to the item(s) loaded on it, and possible severe personal injury or death.
4. It is extremely important that the load placed on any A-Frame cart does not exceed the applicable Safe Working Load Rating. Be sure that when loading the cart it is done in a balanced fashion for both sides of the cart. Never fully load only one side of the cart. Overloading can lead to failure of the A-Frame cart, potentially causing damage to the item(s) loaded on it, and possible severe personal injury or death.
5. Never move the cart with a load on it without strapping the load to the cart using the straps provided. These straps are provided for your safety. Never remove these straps from the cart for any reason. When loading the cart ensure that the strap is moved out of the way of the load. This will ensure that the strap is accessible to secure the load in place once loading is complete.
6. When moving the cart be sure to stand clear of the sides of the cart. During movement loads can become unstable and shift, potentially causing damage to the item(s) loaded on it, and possible severe personal injury or death. Always move the cart by either pushing or pulling from the A-Frame end of the cart. A tongue is provided at one end of the cart to allow the cart to be pulled by a vehicle. Please ensure that when being pulled by a vehicle that the cart is securely attached to the vehicle using properly rated towing straps and associated attachments.
7. Regularly inspect ALL connection bolts to ensure that they remain tight. Tighten any loose bolts if found during inspection.
8. Regularly inspect casters and plastic bumpers for damage and/or excessive wear and replace as necessary.
9. Regularly inspect ALL load straps for any fraying, tearing or damage. Contact Athletica Sport Systems at 1.877.778.5911 immediately for replacement straps if any strap is found frayed, torn or damaged. DO NOT USE the cart for any reason if the straps are damaged.

Contact Athletica Sport Systems at 1.877.778.5911 for all replacement parts.

Tempered Glass Load Chart

Glass Width (ft.)	Glass Height (ft.)	Glass Thickness (in.)	Glass Weight (lb)	Maximum # of pieces of glass per side
4	4	1/2	104	19
4	4	5/8	132	15
4	5	1/2	130	15
4	5	5/8	165	12
4	6	1/2	156	12
4	6	5/8	198	10

Acrylic Load Chart

Acrylic Width (ft.)	Acrylic Height (ft.)	Acrylic Thickness (in.)	Acrylic Weight (lb)	Maximum # of pieces of acrylic per side
4	4	1/2	46	20
4	4	590 Plus™	58	16
8	5	1/2	58	20
8	5	590 Plus™	72	16
8	6	1/2	69	20
8	6	590 Plus™	86	16

Warranty

This Athletica Sport Systems Cart is warranted to be free of defects in materials and workmanship for a period of 1 year from the date of purchase. Please contact Athletica Sport Systems with any questions about the performance of this product.

Contact Us

Canada and International

554 Parkside Drive. Waterloo ON Canada N2L 5Z4
519-747-1856

USA

720 Innovation Drive. Shakopee MN USA 55379
763-249-7465

Replacement parts available.



554 Parkside Drive, Waterloo, Ontario, Canada N2L 5Z4 TEL 519-747-1856
720 Innovation Drive, Shakopee, Minnesota, USA 55379 TEL 763-249-7465

athletica.com



BORDER PATROL



GAMEPLEX

INFINITY Series™



PRO Series™