

Dasher Board / ArenaDeck® Cart

Athletica O&M manual

Thank you for purchasing the Dasher Board / ArenaDeck® Cart

For your safety, please ensure you read these instructions carefully before using. Keep these instructions attached to the cart at all times for reference.

This manual details the assembly and operation of the Dasher Board / ArenaDeck® Cart.

Contact Athletica Sport Systems at 519.747.1856 for all replacement parts.

Component List

Item	Description	Quantity
1	Cart base	1
2	Cart corner uprights	4
3	Cart top frame angles	4
4	Cart end uprights	2
5	3/8" x 4" hex bolts	12
6	3/8" flat washers	24
7	3/8" Nylon lock nut	12

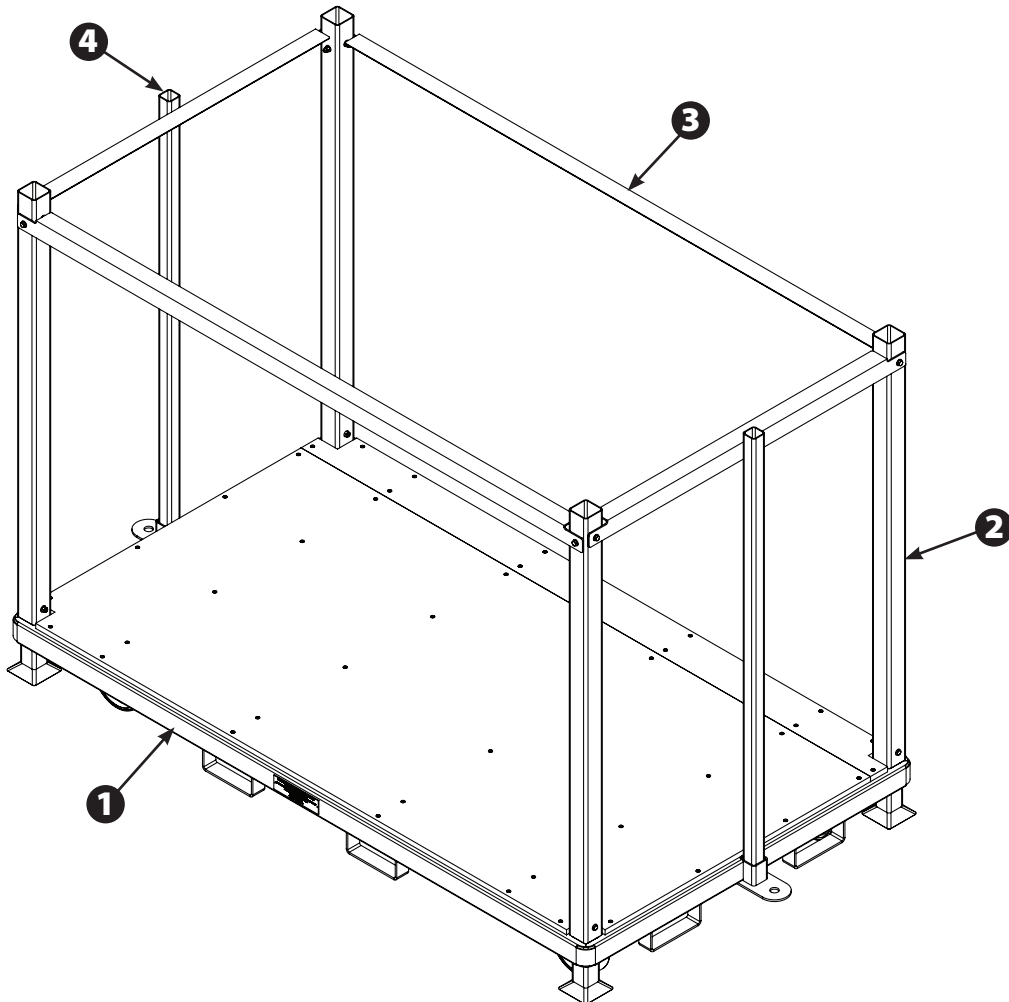

Assembly

1. Unpack all materials in a clean and well lighted work area. Please refer to component list table for list of parts provided.
2. Place cart corner uprights on top of plywood cart base as shown. Fasten in place with 3/8" x 4" hex bolts, 3/8" flat washers and 3/8" nylock nuts. Put the nuts on finger tight at this point.

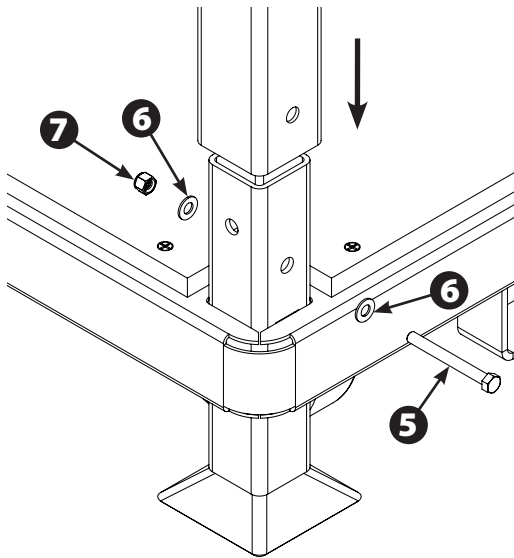

3. Place cart end uprights on top of cart base as shown.

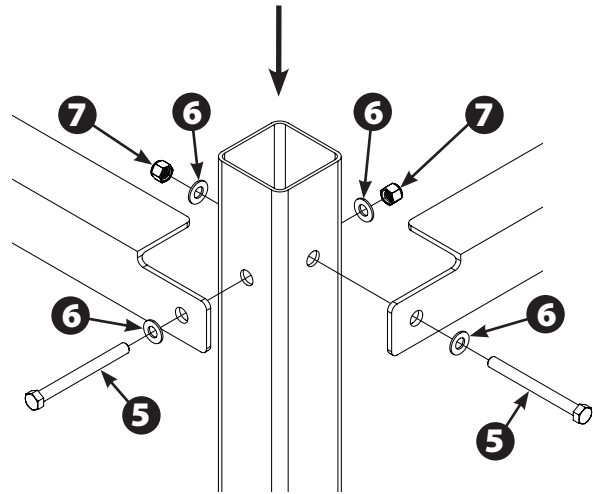
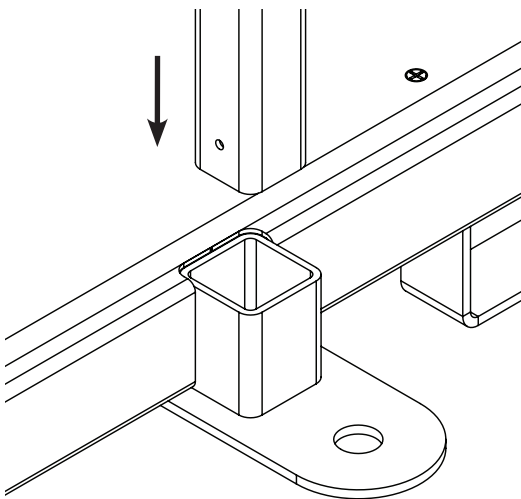

4. Attach cart top frame angles to each upright as shown. Fasten in place to uprights using 3/8" x 4" hex bolts, 3/8" flat washers and 3/8" nylock nuts provided. Repeat for all 4 uprights.
5. Tighten all 3/8" fasteners put in place during steps 3 and 4 using a 9/16" wrench and socket.
6. Your Dasher Board / ArenaDeck® cart is now ready to use. Refer to the Owner/Operator manual for important operational and safety information. Please keep both of these documents available for reference if they are removed from the plywood cart base.

Please continue reading this manual for important operational safety information.

Engineer Stamped Drawing

Upon request, an engineer stamped drawing will be provided to you which describes the dimensions of the Cart and identifies its Safe Working Load Rating.

Name Plate

Please refer to the name plate attached to the cart, which states the Safe Working Load Rating for this cart, as well as the website address and telephone number of Athletica Sport Systems. Please contact us with any questions regarding this product. You can reach us at 519.747.1856 from 8:00 a.m. - 5:00 p.m. Eastern Time, Monday through Friday.

What is the “Safe Working Load Rating”?

The Safe Working Load Rating is the maximum weight that can be loaded onto one (1) Cart (the maximum weight includes the weight of the Cart itself - 625lb). It is extremely important that the load placed on any Dasher Board / ArenaDeck® cart does not exceed the applicable Safe Working Load Rating. Overloading can lead to failure of the Cart, potentially causing damage to the item(s) loaded on it and possible severe personal injury or death. Charts provided on the next page outline the typical weights of various types of ice cover and dasher board panels as well as the maximum number of pieces that can be placed on one (1) Cart. These carts are designed to also be stacked on top of each other to a maximum of two (2) high.

If you are unsure about the safe working load rating for the Dasher Board / ArenaDeck® cart you have purchased, please contact us at 519.747.1856.

Safe Operation and Use of this Dasher Board / ArenaDeck® Cart

1. When lifting materials on and off of the Dasher Board / ArenaDeck® cart use proper lifting techniques to avoid personal injury.
2. Ensure work area is clean and well lighted while loading and unloading the Dasher Board / ArenaDeck® cart.
3. It is important that the Dasher Board / ArenaDeck® cart is positioned on a level floor that is clear and dry and free of debris. If the Dasher Board / ArenaDeck® cart is not positioned on a level floor, loads placed upon or removed

from it could fall, potentially causing damage to the item(s) loaded on it, and possible severe personal injury or death.

4. It is extremely important that the load placed on any Dasher Board / ArenaDeck® cart does not exceed the applicable Safe Working Load Rating stated on the tag. Overloading can lead to failure of the Cart, potentially causing damage to the item(s) loaded on it, and possible severe personal injury or death.
5. Always place the end uprights in the cart when moving the cart. It is strongly recommended that you strap the load on the cart when stacking a cart on top of another cart. This will help prevent the load from becoming unstable when moving. It is the responsibility of the fork lift operator to ensure that the load is stable before lifting and stacking the carts.
Note: Straps NOT provided.
6. When moving the cart be sure to stand clear of the sides of the cart. During movement loads can become unstable and shift, potentially causing damage to the item(s) loaded on it, and possible severe personal injury or death. Always move the cart by either pushing or pulling from the end of the cart. A tongue is provided at one end of the cart to allow the cart to be pulled by a vehicle. Please ensure that when being pulled by a vehicle that the cart is securely attached to the vehicle using properly rated towing straps and associated attachments.
7. Regularly inspect ALL connection bolts to ensure that they remain tight. Tighten any loose bolts if found during inspection. Inspect the castors for signs of wear. Replace as necessary.

Contact Athletica Sport Systems at 519.747.1856 for all replacement parts.

Dasher Board Load Chart

Material	Panel Thickness (inches)	Panel Weight (pounds)	Maximum # of pieces on one cart	Maximum # of pieces on two carts stacked
Typical Dasher Board Panel	7.5	200	12	24 (12 per cart)

ArenaDeck® Load Chart (4ft x 8ft Panels)

Material	Panel Thickness (inches)	Panel Weight (pounds)	Maximum # of pieces on one cart	Maximum # of pieces on two carts stacked
ArenaDeck® Standard Waffle	1	55	50	100 (50 per cart)
ArenaDeck® Fascoat Waffle	1	62	50	100 (50 per cart)
ArenaDeck® Standard Waffle	5/8	30	80	160 (80 per cart)
Homasote®	1	80	50	100 (50 per cart)
Plywood	5/8	62	50	100 (50 per cart)
Plywood	3/4	75	50	100 (50 per cart)

Warranty

This Athletica Sport Systems Dasher Board / ArenaDeck® cart is warranted to be free of defects in materials and workmanship for a period of 1 year from the date of purchase. Please contact Athletica Sport Systems with any questions about the performance of this product.

Contact Us

Canada and International

554 Parkside Drive. Waterloo ON Canada N2L 5Z4
519-747-1856

USA

720 Innovation Drive. Shakopee MN USA 55379
763-249-7465



554 Parkside Drive, Waterloo, Ontario, Canada N2L 5Z4 TEL 519-747-1856
720 Innovation Drive, Shakopee, Minnesota, USA 55379 TEL 763-249-7465

athletica.com



© 2025 Athletica Sport Systems Inc. R1906 Printed in Canada. 101144



BORDER PATROL

CRYSTAPLEX

GAMEPLEX

INFINITY Series™

PRO Series™